

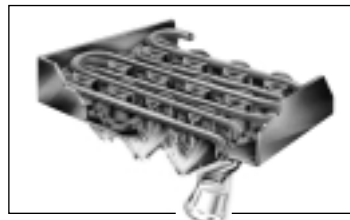

MC 15  
MC 45  
MC1210

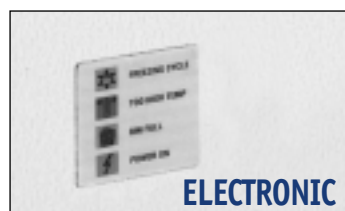

gr 8  
Ø mm 21  
53/64"  
mm 22,5  
7/8"  
Ø mm 25,5  
1"  
**MC S 45**  
0.2 oz.



gr 20  
Ø mm 29,5  
1 5/32"  
mm 30,5  
1 13/64"  
Ø mm 34,5  
1 23/64"  
**MC M 45**  
0.7 oz.

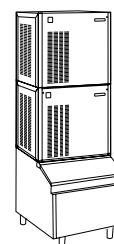
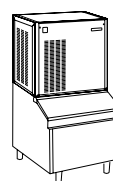

gr 35  
Ø mm 35  
1 3/8"  
mm 38  
1 1/2"  
Ø mm 41,5  
1 5/8"  
**MC L 45**  
1.2 oz.

**Modular  
Gourmet-Cube  
Ice Machine**

**Machine  
Modulaire à  
Glaçons  
Gourmet**

**Kombi  
Gourmetkegel-  
eisbereiter**

**Màquina  
Modulare  
Fabricadora  
de Cubitos  
Gourmet**

**Produttore  
Modulare di  
Ghiaccio a  
Cubetti Gourmet**

	[kg] [lbs] N°	[kg] [lbs] N°	[v/Hz/ph]	[HxWxD mm] [HxWxD inches]	R	
MC L 45 AS	295 650 8400	230 506 6550	230/50/1-400/50/3N	860x1073x534 33 7/8"x42 1/4"x21"	R 404 a	
MC L 45 WS	285 627 8150	230 506 6550	230/50/1-400/50/3N	860x1073x534 33 7/8"x42 1/4"x21"	R 404 a	
MC M 45 AS	310 682 15500	230 506 11500	230/50/1-400/50/3N	860x1073x534 33 7/8"x42 1/4"x21"	R 404 a	
MC M 45 WS	300 660 15000	230 506 11500	230/50/1-400/50/3N	860x1073x534 33 7/8"x42 1/4"x21"	R 404 a	
MC S 45 AS	280 616 35000	230 506 28750	230/50/1-400/50/3N	860x1073x534 33 7/8"x42 1/4"x21"	R 404 a	
MC S 45 WS	270 594 33750	230 506 28750	230/50/1-400/50/3N	860x1073x534 33 7/8"x42 1/4"x21"	R 404 a	

## 2

**Years Warranty  
Ans de Garantie  
Jahre Garantie  
Años de Garantía  
Anni di Garanzia**

Subject to certain limitations and exclusions  
Assujettie aux limites et exclusions prescrites  
Abhängig von Bestimmten Einschränkungen und Ausnahmen  
Sujeta a ciertas limitaciones y exclusiones.  
Soggetta ad alcune limitazioni ed esclusioni

This product qualifies for the following listings:



# MC 45

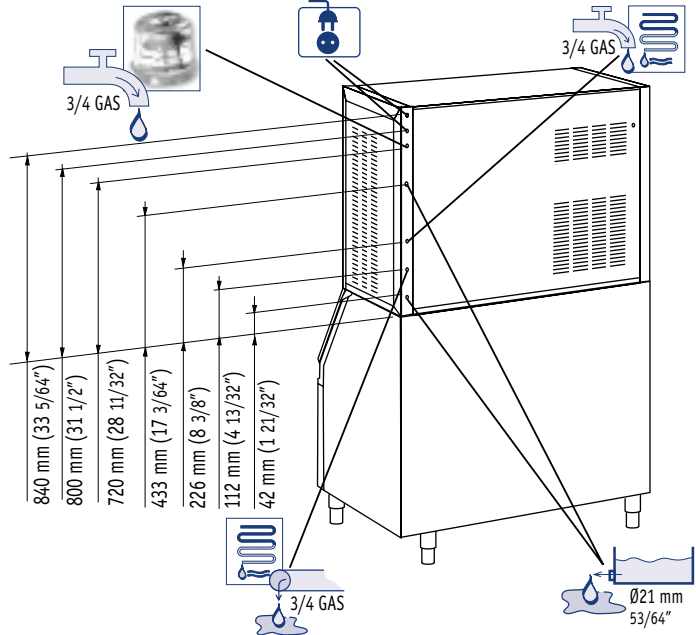
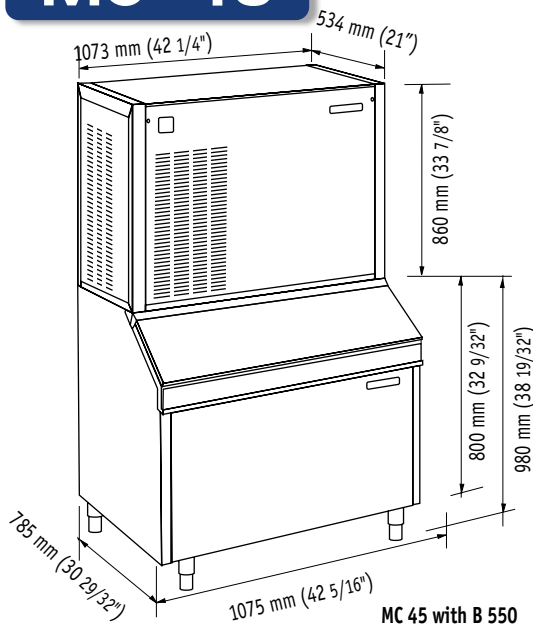

	-C° +C°	[Btu/h] [W]	[Ømm <sup>2</sup> ]	[W]	FUSE	[kWh]	[L/h] [gal/h]	32°C 90°F 21°C 70°F	[kg] [lbs]	[kg] [lbs]
MC L 45 AS		26000 7623	3x1.5 - 5x1.5	2400	20 A	50	27.5 7.2	110 242	125 275	
MC L 45 WS		26000 7623	3x1.5 - 5x1.5	2400	20 A	50	215 56.7	105 231	120 265	
MC M 45 AS		26000 7623	3x1.5 - 5x1.5	2400	20 A	50	27.5 7.2	110 242	125 275	
MC M 45 WS		26000 7623	3x1.5 - 5x1.5	2400	20 A	50	215 56.7	105 231	120 265	
MC S 45 AS		26000 7623	3x1.5 - 5x1.5	2400	20 A	50	27.5 7.2	110 242	125 275	
MC S 45 WS		26000 7623	3x1.5 - 5x1.5	2400	20 A	50	215 56.7	105 231	120 265	

## MC M 45 AIR



°F	90°	70°	60°	50°	
°C	32°	21°	15°	10°	
50°	595	639	661	683	lbs
10°	270	290	300	310	kg
70°	573	617	639	661	lbs
21°	260	280	290	300	kg
90°	463	507	529	551	lbs
32°	210	230	240	250	kg
100	396	440	463	485	lbs
38°	180	200	210	220	kg



## MC M 45 WATER



°F	90°	70°	60°	50°	
°C	32°	21°	15°	10°	
50°	573	617	639	661	lbs
10°	260	280	290	300	kg
70°	551	595	617	639	lbs
21°	250	270	280	290	kg
90°	529	573	595	617	lbs
32°	240	260	270	280	kg
100	507	551	573	595	lbs
38°	230	250	260	270	kg



Machine requires voltage indicated on rating name plate. Failures caused by improper voltage are not considered factory defects. Scotsman products are not designed for outdoor installation. Extended periods of operation at temperatures exceeding the above limitations constitutes misuse under the terms of Scotsman Limited Warranty, resulting in a loss.

La machine doit être raccordée conformément au voltage indiqué sur la plaque signalétique. Les éventuels dégâts causés par un non respect de cette consigne ne peuvent être considérés comme des défauts de fabrication. Les machines à glace Scotsman ne sont pas conçues pour être utilisées à l'extérieur. Le fonctionnement prolongé à des températures supérieures ou inférieures aux limites ci-dessus sont considérées comme une mauvaise utilisation dans le cadre de la garantie Scotsman.

Der Eisbereiter benötigt eine Stromspannung gemäß Geräte-Typenschild. Störungen oder Ausfälle, durch den Betrieb mit falscher Stromspannung sind keine Fabrikationsfehler und fallen nicht unter Garantie. Scotsman Eisbereiter sind nicht für die Installation im Freien geeignet. Der längere Betrieb bei Temperaturen über den obigen Grenzwerten ist eine falsche Anwendung und bedeutet den Verlust der Garantieleistung.

Los requerimientos eléctricos de la máquina estan indicados en la placa de características. Los daños causados por voltajes inadecuados no son considerados defectos de fábrica. La máquinas de hielo Scotsman, no estan diseñadas para trabajar a la intemperie. Largos periodos de funcionamiento a temperaturas que excedan de las limitaciones indicadas, constituyen maltrato de acuerdo con las observaciones de Scotsman.

La macchina richiede il voltaggio indicato sulla targhetta di identificazione. Danni causati da voltaggi diversi non sono considerati difetti di produzione. I prodotti Scotsman non vanno utilizzati all'aperto. Un prolungato periodo di utilizzo al di fuori delle temperature indicate non è consentito e causa l'automatico decadere della garanzia.



**Scotsman**® The one the world relies on.™  
Ice Systems

**USA, Canada, Central and South America**  
Scotsman Ice Systems USA  
775 Corporate Woods Parkway  
Vernon Hills, IL 60061  
Ph: (847) 215-4550 - Fax (847) 913-9844  
E-Mail: customer.service@scotsman-ice.com

**Europe, Middle East and Africa**  
Scotsman Europe - Frimont S.p.A.  
Via Puccini, 22  
20010 Bettolino di Pogliano (Milano) Italy  
Ph: (+39) 02-93960208 - Fax: (+39) 02-93960201  
E-Mail: scotsman.europe@frimont.inet.it

**Asia and Pacific**  
Scotsman Ice Systems-Frimont S.p.A. (R.O.)  
321 Orchard Road #08-05  
Singapore 238866  
Ph: (+65) 738 5393 - Fax: (+65) 738 1959  
E-mail: scotsice@singnet.com.sg

**China**  
Scotsman Ice Systems  
258 Tong Ren Road Golden Tower 7A  
Shanghai - 200040 Peoples' Republic of China  
Ph: (+86) 21-62476056-Fax: (+86) 21-62476126  
E-mail: scotsmansh@online.sh.cn

