

SCOTSMAN

MODULAR AIR, WATER, REMOTE COOLED NUGGET ICE MACHINE

NME654

VOLUME PRODUCTION • 24 HOUR



Based on Air/Water Temperatures	Air-Cooled		Water-Cooled		Remote	
	70°/50° lbs./kg.	90°/70° lbs./kg.	70°/50° lbs./kg.	90°/70° lbs./kg.	70°/50° lbs./kg.	90°/70° lbs./kg.
NME654	700/317	520/236	745/338	605/274	615/278	560/254

SCOTSMAN'S NEW NUGGET ICE MACHINES with AutoSentry™

- AutoSentry™ Monitoring System constantly checks workload on gearbox shutting down system before a problem develops preventing costly repairs.
- Electronical conductivity water sensor eliminates low or no water failures and cannot be affected by adverse water conditions.
- Plastic drain pan with larger outlet provides greater ability to quickly channel water away preventing particulate build-up and rust.
- Rust and restriction free drain system features one-piece plastic drain tubes with larger ID for obstruction-free water flow.
- Durable, high grade stainless steel construction with massive, self-aligning spherical roller bearings; patented double-flight auger that evenly distributes the load; and heavy duty direct drive gearbox for high reliability and long life.

WARRANTY See your dealer for complete warranty details.

- 3 years parts on all components.
- 2 years labor on all components.
- 5 years parts on compressor.

BIN OPTIONS:



BIN: HTB350



BIN: BH550



BIN: BH800



SCOTSMAN MODULAR BINS					
Model Number	Dimensions W"xD"xH"	ARI Bin Capacity lbs.	Application Capacity lbs.	Finish [~]	Ship Weight lbs./kg.
HTB250	30 x 31.5 x 22.5	190	250	HTB	80/36
HTB350	30 x 31.5 x 29.5	250	350	HTB	90/41
HTB555	30 x 34.5 x 44.5	420	535	HTB	110/50
BH550S-C	30 x 31.5 x 44	410	520	SS	140/64
BH800S-C*	42 x 31.5 x 44	580	740	SS	165/75
BH900S-C*	48.2 x 33.75 x 44	740	940	SS	185/84
BH1366S**	56 x 40 x 54	1030	1320	SS	380/172
BH1666S**	60 x 40 x 60	1250	1600	SS	410/186

Please add 6" to Height for Legs

[~](HTB) Polyethylene Exterior and Interior—Grey color. *See Price Schedule for Appropriate Bin Top (SS) Stainless Steel with Polyethylene liner. **Accepts two machines side by side

 Certified & rated in accordance with ARI standard 820-95

This product qualifies for the following listings:

Rated in accordance with ARI standard 820-95

Scotsman[®]
A WELBILT[™] COMPANY

Ice Machine Specifications

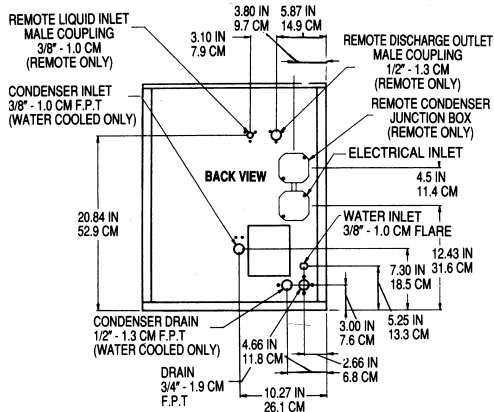

BACK VIEW - WATER & REMOTE

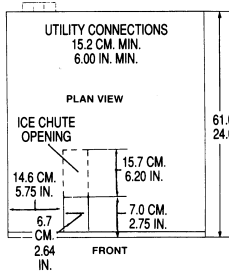

INSTALLATION NOTE:
Allow 6" minimum space at back for ventilation and utility connections.

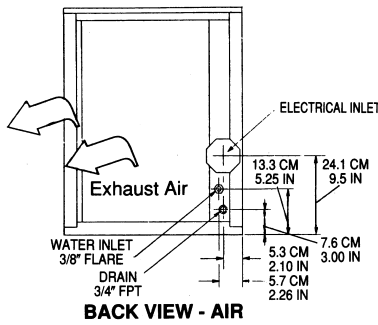

FRONT VIEW

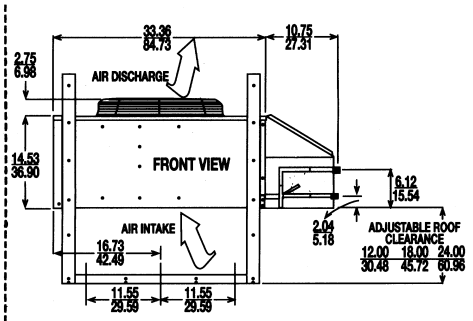
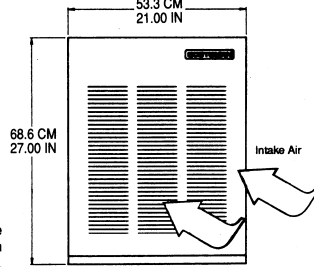

⚠️ DUAL CIRCUIT CONNECTIONS ARE FOR ERC302-32A AND ERC402-32A ONLY

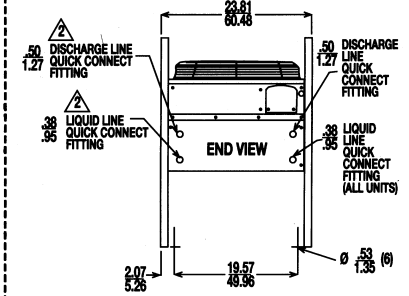

ERC101-1A remote condenser

All models: Dimensions: W x D x H Unit: 21" x 24" x 27" Shipping Carton: 28" x 25" x 32"

Model Number	Condenser Unit	Basic Electrical Volts/Hz/Phase	Max. Fuse Size or HACR Circuit Breaker	Comp. HP	Circuit Wires	Min. Circuit Ampacity	Shipping Weight lbs./kg.	Power Consumption KWH/100 lbs. 90°/70°F	Water Usage Gallons/100 lbs.	
									Potable 90°/70°F	Condenser 90°/70°F
NME654AS-1A	AIR	115/60/1	30	3/4	2	19.5	205/93	5.3	12	-
NME654WS-1A	WATER	115/60/1	30	3/4	2	18.3	200/91	4.1	12	88.4
NME654RS-1A	REMOTE	115/60/1	30	3/4	2	22.5	220/100	NA	12	-

All units with Stainless Steel finish.
Refrigerant: R-404A.

REMOTE CONDENSER - Comes with adjustable legs
Dimensions: W x D x H: 45" x 22.12" x 29.25"

Model Number	For Use With	Cond. Unit	Finish Basic	Electrical Volts/Hz/Phase	No. of Wires	Min. Circuit Ampacity	Max Fuse Size or HACR Circuit Breaker
ERC101-1A	(1) NME654	Air	Galvanized	115/60/1	2	6.0	15

PRE-CHARGED REFRIGERANT TUBE KITS: 25-Foot, RTE25-25 • 40-Foot, RTE40-40 • 75-Foot, RTE75-75
Refrigerant: R-404A.

Scotsman's ice machines are not designed for outdoor installations. Scotsman remote condensers are designed for outdoor installations.

Machine requires voltage indicated on rating name plate. Failures caused by improper voltage are not considered factory defects. Extended periods of operation at temperatures exceeding limitations constitutes misuse under the terms of Scotsman Manufacturer's Limited Warranty, resulting in a loss of warranty coverage. Specifications and design are subject to change without notice.

Consult Your Local SCOTSMAN Representative At:

IMPORTANT OPERATING REQUIREMENTS:

	Minimum	Maximum
Air Temperatures	50°F (10°C)	100°F (37.7°C)
Water Temperatures	40°F (4.4°C)	100°F (37.7°C)
Remote Cond. Temps	-20°F (-28.9°C)	120°F (48.9°C)
Water Pressures	20 PSIG	120 PSIG
Electrical Voltage	-5%	+10%

YOU'LL VALUE THE DIFFERENCE.™

775 Corporate Woods Parkway • Vernon Hills, IL 60061 • 1-800-SCOTSMAN • (847) 913-9844
Visit our website at: www.scotsman-ice.com • E-mail: customer.service@scotsman-ice.com

Scotsman
A WELBILT™ COMPANY